

BOAT LIFT

Via Alba-Narzole, 19
Diano d'Alba (CN) - 12055

www.boatlift.it
info@boatlift.it
+39 (0)173 500357

HANDLING AND LIFTING SYSTEMS



Boat hoists



MAIN FEATURES

- Engineering and manufacturing process completely internalised
- Machinery compliant to 2006/42/CE guidelines and to FEM / UNI EN standards
- Customized dimensions according to customer's needs
- Soundproofed diesel engine compliant to current regulations
- Anti-corrosion painting compliant to C5m cycle
- Radio remote control with LCD colour display
- Partial/total weight reading system
- Load balancing 60% / 40%
- Independent and electronically synchronized winches
- Double proportional lifting speed unloaded / loaded
- Lifting belts with safety factor 7:1
- Double proportional motion speed unloaded / loaded
- Industrial tyres, air-inflated or equipped with specific filling
- Pipes and fittings in galvanized painted steel
- Hydraulic oil filtering
- Electrical supply by 24 VCC battery
- Remote assistance in real time by M2M system

| **BL25-60** |

BL75-160 |

BL130-430 |

BL440-1200 |

STEERING

Front-wheels steering

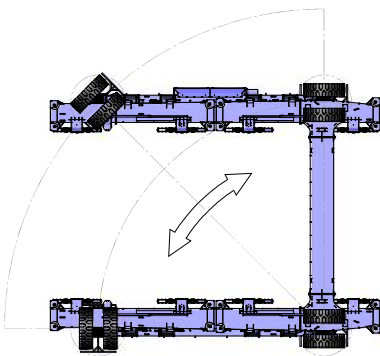

Rear-wheels steering

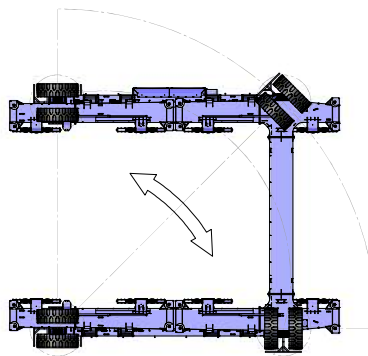

All steering

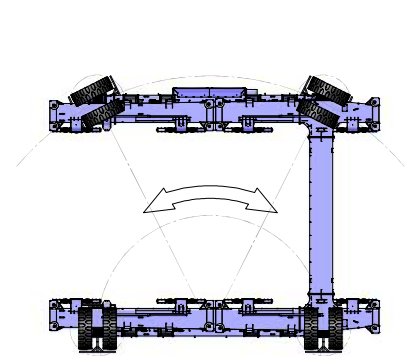

Diagonal march

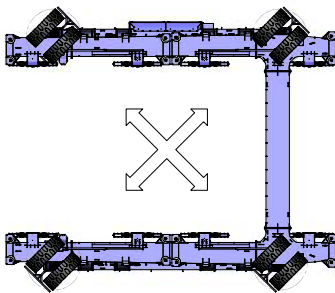

Crab steering

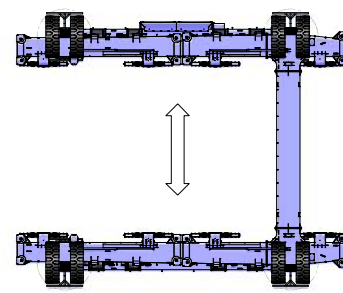

OPTIONAL

- U-shaped upper-beam for sailboats rigging
- Variable track by hydraulic expansion system
- Full-electric version equipped with lithium battery with guaranteed autonomy according to predicted duty cycles
- Driver cabin
- Auxiliary jib crane
- Windmeter
- Workspace lighting with LED lights
- Trunnion pin system for increased structure resistance on uneven surfaces
- "Dynamic Steering Control" system via motorized turntables for increased manoeuvrability
- Pipes and fittings in stainless steel